



Issue No 36

4th March 2022

**Important Dates:**

**Monday 7th March**

Celebration of Music  
Winter Gardens

**Monday 14th March**

Assessment week for Year 10 & Year 11

**Friday 18th March**

Non-Uniform Day  
Bring a £1

**Wednesday 23rd March**

Year 7 Parents' Evening

**Monday 28th March**

Assessment week for Year 7, 8 & 9

**Friday 1st April**

School closes for Easter

**Please see Page 4 for all the dates of Parents' evenings this year.**

Email [admin@millfield.lancs.sch.uk](mailto:admin@millfield.lancs.sch.uk)

Website: [www.millfield.lancs.sch.uk](http://www.millfield.lancs.sch.uk)

Twitter page @millfieldhighsc

#BeExceptional

#TeamMillfield



# Millfield MESSENGER

Belvedere Road, Thornton Cleveleys, FY5 5DG

Telephone 01253 865929



Dear Parents and Carers

On 24th February schools received updated 'Living with Covid' guidance; here is a summary of the changes:

- Twice-weekly lateral flow tests no longer need to be done. In the event of a Covid outbreak these may be reintroduced.
- Face coverings no longer need to be worn, however if individuals want to wear them their wishes will be respected. In the event of a Covid outbreak, they may be reintroduced.
- If your child has any of the three main Covid symptoms, do not send them to school and book a PCR test. If positive, they should self-isolate for a minimum of 5 days and can take lateral flow tests from day 5. The most up to date guidance can be found here: <https://www.gov.uk/government/publications/covid-19-people-with-covid-19-and-their-contacts/covid-19-people-with-covid-19-and-their-contacts>
- In the unlikely event of this happening, all schools have the right to refuse attendance for a student or member of staff presenting with a confirmed or suspected case of Covid.

We are incredibly proud of everything we have accomplished over the last two years, with your support, to not only protect our community and our families but continue to educate our students to a high standard. What is truly exciting, as we emerge from the protective restrictions of the pandemic, is the restarting of all the superb extracurricular opportunities, personal development and wellbeing events, some of which are detailed below:

We welcomed Theresa Saxon from Lancaster University, who delivered an informative lecture to our Year 10s and 11s on the topic of Dickens, to help students develop their contextual knowledge of the Victorian era.

Miss Kilmartin, Head of Dance, organised a dance workshop, delivered by the Lowry Centre for Advanced Training, which gave some of our key stage 3 and key stage 4 talented dancers a taster of courses they have on offer.

Mrs Devaney, Head of Art, had the pleasure of preparing artwork for the Young Seaside Art Exhibition. Our talented students have had their artwork chosen to be displayed at Blackpool and The Fylde College. The exhibition is free and is open to the public from Friday 28th February until Friday 25th March 2022.

This week has been National Careers week. We have had a range of exciting careers events for all students, including:

- Careers and Finance Assemblies: Mrs Regan
- Form time: Careers, including local labour market information
- Tuesday: Year 10 Mock Interview Day, with local employers
- Wednesday: Year 8 Resilience Day
- Thursday: Careers Fair for all year groups – local businesses, colleges and universities in school
- All subjects: Discussed what jobs their subject area can lead to.

Finally, a huge thank you and well done to everyone who donated to raising funds for Isabelle Grundy; you all raised an incredible £904!

We use Twitter to celebrate the achievements of our students and remind parents of events, you can follow us at @millfieldhighsc.

Best wishes

*N. Regan*

Nicola Regan  
Headteacher

## Be Exceptional!

# KEY STAGE 3



Welcome back to all our Year 7 students from half term. We hope you've all had a well-deserved break and kept safe from the number of storms we have had. First of all, thank you to everyone who has sent in donations for children's books to support our world book day. There was a book carnival held in the library where lots of exciting activities took place. It was clear to see that the students really enjoyed the various stalls and competitions.

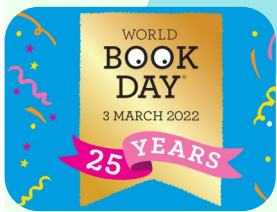

In Dance, students have been choreographing their own Bollywood dance to the Slumdog Millionaire hit 'Jai ho'. In Computer Science, students are designing their own fit bit by creating their own micro bit programming. In Design and Technology their current topic is woodwork where students are building their own maze.



In Year 8, students have had the first themed PSHE super learning day of the year. On this day students were able to receive some basic first aid training, develop skills for futures careers and look at ways of improving their mental health. We were also very lucky to have members of the local Women's Aid team who discussed the importance of consent.

It has also been Careers Week for all students. In lessons they have been discussing possible careers and how each subject can develop their skills. The career convention was fantastic for all years; students were able to interact with employers and further and higher education providers.



The Graduation and Exceptional Awards programmes are now coming to the end. Students have until the May half term to complete the tasks to see which grade they will graduate with. Special considerations will be made for attendance this year, but tasks will need to be completed. Final amendments are being made to the graduation ceremony and party day. Distinction star students will also be choosing their end of year trip after the Easter holidays. Students will not want to miss out when the ceremonies come around!



Miss Miller Crook - Year 7 Progress Lead  
Mr. Booth - Head of Aspirations  
Mr. Smith - Head of Personal Development



# KEY STAGE 4

We have had several important events and opportunities happening over the last two weeks for students in Key Stage 4.



Last week we launched the process for appointing a new senior student team including Head Boy and Head Girl and Deputies. This is a fantastic opportunity to help shape the direction of the school, to support the school community and to improve leadership and team work skills which are of great value when applying to colleges, universities and jobs. Any Year 10 student wishing to apply should write a letter explaining why they would be suitable for the role and what they would hope to achieve in the role.

**The deadline for the letter of application to be submitted to me is Friday 18th March.**

Year 10 had a very successful mock interview day on Tuesday. They looked exceptionally smart and our interviewers were impressed with how mature and thoughtful they were in their responses.



On Saturday, three of our Year 11 girls will be attending the International Women's Day

Festival at Blackpool Sixth form. They have been surveying students in Years 9, 10 and 11 about the issue of equality and will use the results from this in workshops and discussions with other young women from the area.

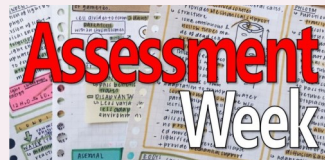

A brief reminder that March mocks for Year 11 and assessment week for Year 10 start on

14th March and students should be revising hard in preparation for these.

Miss C. Gower  
Head of Key Stage 4

# Deputy Headteacher's Maths Challenge



## Maximum Box

What is the maximum volume of an open top box that can be made from a 20 x 20 cm piece of paper?

Cut out a 1cm by 1cm square and calculate the volume (results in table below).

Try different size corner squares and put your results in a table:

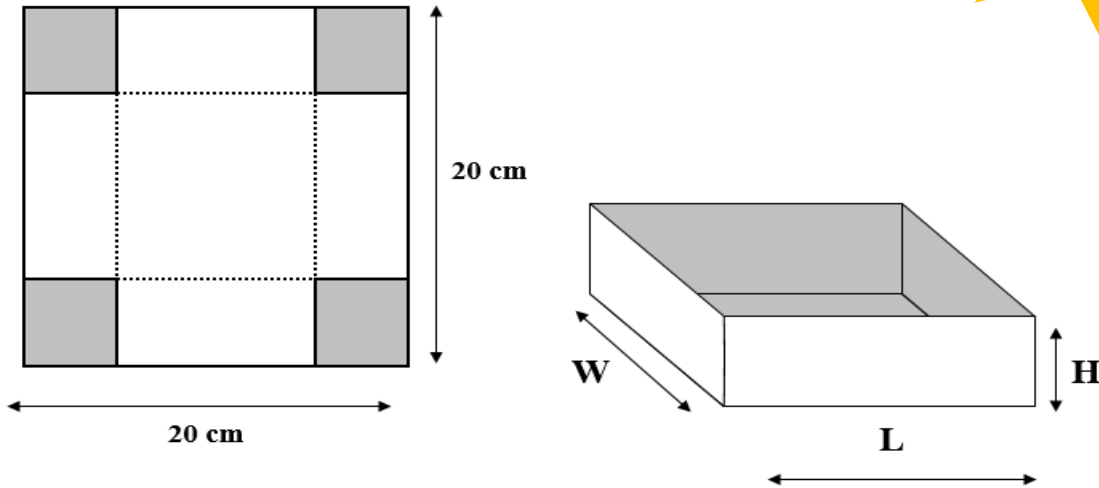

Try different size corner squares and put your results in a table:

Corner Square	Dimensions of the Box (cm)			Volume (cm <sup>3</sup> )
	Length (L)	Width (W)	Height (H)	
1 x 1	18	18	2	648
2 x 2				

If you do not use whole number measurements for the corner square, can you make the volume larger?

Please email your solutions to Mr Humphreys at:  
[b.humphreys@millfield.lancs.sch.uk](mailto:b.humphreys@millfield.lancs.sch.uk)

### DATES FOR 2022

Celebration of Music - 7th March 2022

Y11 Mock Exams— 14th -18th March

(Timetable on website)

Y7 Parents' Evening - 23rd March 2022

Y8 Parents' Evening - 18th May 2022

### WORK EXPERIENCE



#### Year 10 Work Experience

2022

The dates for the Work Experience will be

**21st March – 1st April 2022**

Any problems, please send students to A50 to see me—Mrs Draper.

# Home - Learning

## Definition – why is Home-Learning important?

Home-learning bridges the gap between school and home. Here at Millfield we believe in a collaborative approach, which allows students, teachers and parents to monitor the progress of their child in the learning process. Common home-learning assignments may include required reading, writing or typing projects, mathematical exercises to be completed, information to be reviewed before a test, or other skills to be practised.

As a parent, here are a few things you may wish to consider:

- ⇒ **Home-learning improves student achievement.**  
Studies show that home-learning improves student achievement in terms of improved grades, test results, and the likelihood to attend college
- ⇒ **Home-learning helps to reinforce learning and develop good study habits and life skills.**  
Everyone knows that practise makes perfect. Students typically retain only 50% of the information teachers provide in class, and they need to apply that information in order to truly learn it.
- ⇒ **Home-learning allows parents to be involved with their child's learning.**  
Thanks to take-home assignments, parents are able to track what their children are learning at school as well as their academic strengths and weaknesses.

Here at Millfield we celebrate excellence and home-learning is no exception:-

Congratulations go to students in Mrs Winterson's electronics class who produced an outstanding component identification sheet in which they have highlighted key words and symbols for each component.

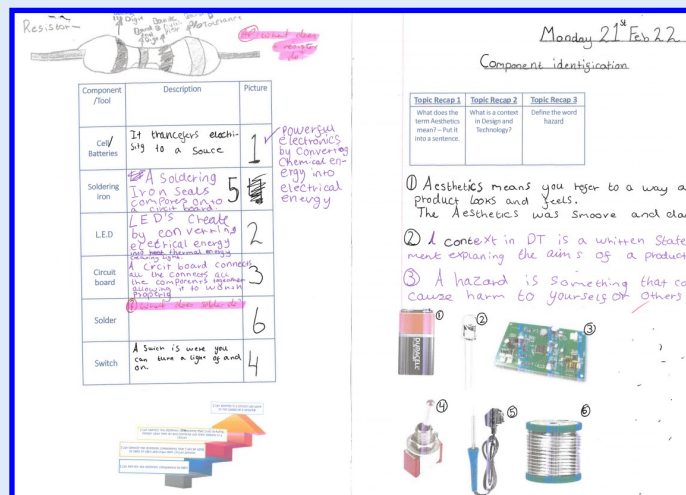

## Reminder

In order to support your child with their home learning, please regularly log into Talaxy to monitor the tasks that have been set and remind your child to complete them. The home learning policy can be viewed on our school website; this explains how much home learning your child should be set each week and the types of tasks they could be set.

If you require any further information about our home-learning or how to register for Talaxy, please visit the schools website: -

<http://www.millfield.lancs.sch.uk/parents/online-parental-reporting/>

Mr. G. Wood

Lead Practitioner of Teaching and Learning (Technology).



## HOT CHOCOLATE WITH THE HEADTEACHER

Year 8

- Alecia Atkinson
- Ava Atherton
- Jonjo Edwards
- Declan Uchebraye
- Ellie Greaves
- Brooke Cooper

All of the students have been nominated by Mr. Tyson for their excellent work in I.C.T

*Be Exceptional!*

# COMIC RELIEF

**NON UNIFORM DAY**  
**FRIDAY 18TH MARCH**  
**BRING A £1**



## Student Council

The student council have been discussing issues that they feel affect them and many other students in school on a daily basis.

### Uniform

The uniform policy has been a big discussion point in previous student council meetings. Students have been eager to share their views on gender neutral uniforms, wearing PE kits on days when students have PE and the idea of introducing blazers for all year groups. There were positive and negative points made and arguments both for and against each of these ideas. If ANY student would like to have a say or input on these matters, please speak to Mr Booth or any member of the student council.



### Vegan food

Another key discussion point has been the availability of vegetarian and vegan food in the canteen, in particular hot food. Many students have requested that there are more options on a daily basis in order to meet the needs and dietary requirements of students. The student council will be holding a meeting with the canteen staff on Wednesday 16th March. Again, if ANY student would like to have a say or input on these matters, please speak to Mr Booth or any member of the student council.

### Road safety

Road safety has been raised by students. Their concerns center around appropriate parking and having safe areas to cross the road. In the coming weeks, the student council will be writing a letter to all parents to voice their concerns and provide recommendations to ensure that all children feel safe in the local area.



These issues raised have provided the student council with a fantastic opportunity to meet with many different members of staff to discuss and debate solutions to the problems that matter most to them.

# Teaching and Learning Tips

## Learning, self-esteem and change

Year 8 students have been discussing self-esteem and how to make positive changes as part of their recent resilience day.

It is important to remember the benefits of a growth mindset and how this can lead to progress in school. It is **effort** and **good study habits** which lead to success.

Here are some growth mindset affirmations which would be useful to discuss at home:

- Today is another chance to be better.
- Don't stop until you are proud.
- If you never try, you will never know what you are truly capable of.
- Your attitude determines your success.
- Strive for progress, not perfection.
- Every mistake you make is an opportunity for progress.
- You have not failed unless you have stopped trying.



Miss J. Copping  
Lead Practitioner of Teaching & Learning (Foundation Subjects).

## Be Exceptional!

### HOT CHOCOLATE WITH THE HEADTEACHER

Year 9

- Madison Hindley
- Stephanie Shaw
- Olivia Probin
- Theo Quinnell

All of the students have been nominated by Mrs. Hill for their excellent work in Music.

Be Exceptional!

Not sure what your son or daughter is studying in school this term?



Have a look on our school website where you will find the 'Learning Journeys' for every subject. The Learning Journeys give details about what is being studied each half term from the start of Year 7 right up to when students leave in Year 11.

## Star Students



★ Zara Grant - for accessing lessons and writing a wonderful Dystopian story in English.

★ Kyle Woods - for excellent work in interventions, particularly his studies on Dystopian literature and progress with time calculations.

## Book Week

As part of book week, students took part in a Harry Potter themed escape room. Well done to the marauders: Nicole, Maria & Esme for cracking the code and lifting the sleeping curse placed on Hogwarts! Exceptional effort! #TeamMillfield #BeExceptional



## Young Seaside Art Exhibition



Exhibition today. Look how amazing this work looks! This is just a snapshot of work from some of the talented students we have at Millfield. A special congratulations to the two winners from school, Amy Depledge and Amber Davis.

## Dance Workshop

Some of our KS3 and KS4 dance students enjoyed a CAT Lowry taster workshop which gave them a taster of the course and classes. It was a great morning - well done to all those involved! Thank you to Miss Kilmartin for organising the event. #BeExceptional #TeamMillfield



## Well done!

Mrs. Devaney had the pleasure of preparing some artwork for the Young Seaside Art Exhibition today.

## Art Club

We discussed miniature art and how different artists create and sell. Then they had 40 minutes to create their own.



Fantastic effort in the time they had, experimented with mixing colours and different painting techniques. Well Done!



# Careers Week

As part of our continued commitment to raising aspirations and creating well-informed and resilient young people we recently held the Millfield Careers Week Monday 28th February. Students learnt about how their subjects link to career opportunities and learnt about the soft skills that are important in industry.

During the Careers Week, Year 10 students took part in mock interviews to help prepare them for the world of work. Interviewing the students were representatives from B&F College, Sixth Form College, Virgin, NHS, Victrex, Westinghouse and H.S.B.C.

On Thursday 3rd March, our annual Careers Convention was once again a great success with 22 companies, colleges, universities and services attending to give our students information and guidance on helping them choose their career path. Thank you to all delegates who made the day so successful! All students met employers, further and higher education providers, asking them questions about future career pathways. Mrs Hayley Arthur - Careers Advisor, was also on hand to provide extra careers guidance.

The Careers Week also gave students the chance to learn about in career options linked to their subjects. As part of further careers support at Millfield, teachers guided students on how to navigate CAREERPILOT - a website designed to support parents and students with careers information. Further information about CAREERPILOT can be found on the school website.

Thanks to all the local employers and colleges for helping to support our careers programme. An excellent collaboration between education and business! We also recently completed the Careers Evaluation process that looks to see if schools are compliant with the statutory careers Gatsby Benchmarks and Millfield are meeting all the benchmarks. An excellent achievement!



## Mock Interview Day

Our Year 10 students prepared for their Work Experience during a mock interview day with staff from HSBC, Victrex, NHS, Virgin Money, NW Financial Solutions, Westinghouse, Blackpool and Fylde College, Blackpool 6<sup>th</sup> Form, . The students were invited to come to school dressed for an interview and received feedback on their performances following the interviews. The interviewers said they were 'impressed with how polite and well prepared our students were'.





# Pastoral and Wellbeing



At National Online Safety, we believe in empowering parents, carers and trusted adults with the information to hold an informed conversation about online safety with their children, should they feel it is needed. This guide focuses on one of many apps that we believe trusted adults should be aware of. Please visit [www.nationalonlinesafety.com](http://www.nationalonlinesafety.com) for further guides, hints and tips for adults.

## What Parents & Carers Need to Know about

# YOUTUBE

YouTube is a video-sharing social media platform that allows billions of people around the world to watch, share and upload their own videos with a vast range of content – including sport, entertainment, education and lots more. It's a superb space for people to consume content that they're interested in. As a result, this astronomically popular platform has had a huge social impact: influencing online culture on a global scale and creating new celebrities.

### INAPPROPRIATE CONTENT

YouTube is free and can be accessed via numerous devices, even without creating a YouTube account. Some content is flagged as 'age-restricted' (requiring the user to be logged into an account with a verified age of 18), but children can still view some mildly inappropriate material. This can include profanity and violence, which some young users may find upsetting.

### CONNECT WITH STRANGERS

YouTube is a social media platform which allows people to interact with other (usually unknown) users. Account holders can leave comments on any video they have access to, as well as messaging other users directly. Connecting with strangers online, of course, can potentially lead to children being exposed to adult language, to cyberbullying and even to encountering online predators.

### SUGGESTED CONTENT

YouTube recommends videos related to what the user has previously watched on their account, aiming to provide content that will interest them. This is intended to be helpful but can also lead to binge-watching and the risk of screen addiction, especially if 'auto-play' is activated. Users without an account are shown popular videos from the last 24 hours, which might not always be suitable for children.

### HIGH VISIBILITY

Content creators can also be put at risk – especially young ones who try to make their online presence as visible as possible. Creating and uploading content exposes children to potential harassment and toxicity from the comments section, along with the possibility of direct messaging from strangers. Videos posted publicly can be watched by anyone in the world.

### TRENDS AND CHALLENGES

YouTube is teeming with trends, challenges and memes that are fun to watch and join in with. Children often find these immensely entertaining and might want to try them out. Most challenges tend to be safe, but many others may harm children through either watching or copying. The painful 'salt and ice challenge', which can cause injuries very quickly, is just one of many such examples.

### SNEAKY SCAMMERS

Popular YouTube channels regularly have scammers posing as a well-known influencer in the comments section, attempting to lure users into clicking on their phishing links. Scammers impersonate YouTubers by adopting their names and profile images, and sometimes offer cash gifts or 'get rich quick' schemes. Children may not realise that these users are not who they claim to be.

## Advice for Parents & Carers

### APPLY RESTRICTED MODE

Restricted Mode is an optional setting that prevents YouTube from showing inappropriate content (such as drug and alcohol abuse, graphic violence and sexual situations) to underage viewers. To prevent your child from chancing across age-inappropriate content on the platform, we would recommend enabling Restricted Mode on each device that your child uses to access YouTube.



### TRY GOOGLE FAMILY

Creating a Google Family account allows you to monitor what your child is watching, uploading and sharing with other users. It will also display their recently watched videos, searches and recommended videos. In general, a Google Family account gives you an oversight of how your child is using sites like YouTube and helps you ensure they are only accessing appropriate content.

### CHECK PRIVACY SETTINGS

YouTube gives users the option of uploading videos as 'private' or 'unlisted' – so they could be shared exclusively with family and friends, for example. Comments on videos can also be disabled and channels that your child is subscribed to can be hidden. If your child is only uploading videos that are protected as 'private', they are far less likely to receive direct messages from strangers.

### CHECK OTHER PLATFORMS

Influential content creators usually have other social media accounts which they encourage their fans to follow. Having an open discussion about this with your child makes it easier to find out how else they might be following a particular creator online. It also opens up avenues for you to check out that creator's other channels to see what type of content your child is being exposed to.

### MONITOR ENGAGEMENT

YouTube is the online viewing platform of choice for billions of people, many of them children. Younger children will watch different content to older ones, of course, and react to content differently. You may want to keep an eye on how your child interacts with content on YouTube – and, if applicable, with content creators – to understand the types of videos they are interested in.

### LIMIT SPENDING

Although YouTube is free, it does offer some in-app purchases: users can rent and buy TV shows and movies to watch, for example. If you're not comfortable with your child purchasing content online, limit their access to your bank cards and online payment methods. Many parents have discovered to their cost that a child happily devouring a paid-for series quickly leads to an unexpected bill!

### Meet Our Expert

Clare Godwin (a.k.a. Lunawolf) has worked as an editor and journalist in the gaming industry since 2015, providing websites with event coverage, reviews and gaming guides. She is the owner of Lunawolf Gaming and is currently working on various gaming-related projects including game development and writing non-fiction books.



National Online Safety®

#WakeUpWednesday



[www.nationalonlinesafety.com](http://www.nationalonlinesafety.com)



@natonlinesafety



/NationalOnlineSafety



@nationalonlinesafety

Users of this guide do so at their own discretion. No liability is entered into. Current as of the date of release: 26.01.2022

Mr. Deville

Assistant Headteacher in charge of Behaviour and Safeguarding

## Can you help?

I am currently in the process of redesigning the Millfield prospectus for 2022/23 and I am looking for some parents who would be willing to write a testimonial about Millfield that I could include. It need only be a few sentences or a couple of paragraphs about what you as a parent like about Millfield and why you chose the school.



All of the parents who write a testimonial that is included in the prospectus will receive a box of chocolates as a thank you. If you feel that you would like to contribute, please can you contact me on my email [j.fawcett@millfield.lancs.sch.uk](mailto:j.fawcett@millfield.lancs.sch.uk) with the subject line Millfield Testimonial.

Many thanks.

Mrs. J. Fawcett Assistant Headteacher

# Year 8 Resilience Day



YEAR 8  
RESILIENCE DAY



# *Be Exceptional!*

MILLFIELD SCIENCE & PERFORMING ARTS COLLEGE  
PRESENTS

IN AID OF THE WINTER GARDENS TRUST

CELEBRATION OF  
**MUSIC**  
2022

*Good Times*

**OPERA HOUSE**

BLACKPOOL

MONDAY 7<sup>TH</sup> MARCH 2022

6:30PM - 9:00PM

A CELEBRATION OF MUSIC FEATURING PUPILS FROM  
SCHOOLS ACROSS THE FYLDE COAST

ADULTS £9.00 CHILD £5.00

BOOK ONLINE - [WWW.WGBPL.CO.UK](http://WWW.WGBPL.CO.UK)

OR CALL THE BOX OFFICE ON

01253 629600

BOOKING FEES APPLY.

OR VISIT : BOX OFFICE AT THE WINTER GARDENS BLACKPOOL -NO BOOKING FEE

